

## MAX-SEAL BUTTERFLY VALVES

Flo-Tite's

MAX-SEAL SERIES of

# High Performance Butterfly Valves

Available with Soft and Metal Seating



20in Lug



6in Wafer

Size Range  
2" thru 42"

ANSI Class 150/300

**MODEL.BW630**

As a part of the Flo-Tite Group, Max-Seal High Performance Butterfly Valves are backed by the resources and experience of over thirty five years of process valve and automation experience.

## VALVE DESIGN FEATURES

**Flo-Tite**'s high performance butterfly was introduced in 1987. The MAX-SEAL valve is the result of years of experience in the design and manufacture of ball and butterfly valves. All valves are leak tested per MSS-SP61 standards, and tagged per MSS-SP25 & API 609B specifications. Testing per API 598 can be provided as an option.

### 1) Mounting Top Flange

Meets ISO5211 pattern providing low cost "Near Direct Mount" actuation capability.

### 2) Extra Long Neck

Provides path for heat dissipation and allows space for insulation.

### 3) Stem Seal

Self-lubricating PTFE V-rings prevent leakage to atmosphere.

### 4) Retainer Cover

Maintains seat integrity prior to installation. Interchangeable with any seat option. Standard surface finish is 125 to 200 AARH. Compatible with both standard and spiral-wound gasket designs.

### 5) Retainer Fasteners

SS set screws provide ease of seat replacement.

### 6) Bottom Flange Cover

Equalizes pressure under shaft, eliminating "piston" effect at higher pressure.



### 7) Blow-out Proof Shaft

17-4Ph stainless steel stem provides excellent strength, alignment and rigid support to disc.

### 8) Easy-Access Packing Gland

Provides means for packing adjustment, even when "Direct-mount" actuation and insulation are utilized.

### 9) Top Stem Bearings

Top RPTFE/SS self-lubricating bearings provide excellent stem support and shaft alignment.

### 10) Soft Seat

One-piece solid RPTFE static and dynamic seat design seals at both high and low pressures.

### 11) Over Travel Stop

Integrally cast into body, prevents disc from rotating in wrong quadrant and damaging seat

### 12) Bottom Stem Bearings

Bottom RPTFE/SS self-lubricating bearings provide excellent stem support and shaft alignment.

### 13) Wedge Pins

Provide positive mechanical attachment of disc to shaft.

### 14) Bottom Packing

The lower shaft utilizes seal in the body to prevent external leakage and simplify valve maintenance.

## Flo-Tite Max-Seal 630/730 Series High Performance Butterfly Valves, serving Multi-National end users in a wide range of applications in many industries including:

- |                            |                           |                                      |
|----------------------------|---------------------------|--------------------------------------|
| 1 Chemical & petrochemical | 5 Food industries         | 9 Steel & iron industries            |
| 2 Power generation plants  | 6 LNG, HRSG industries    | 10 Pulp & paper plants               |
| 3 Ship building industries | 7 Oil refinery industries | 11 Coal & mining industries          |
| 4 Fiber industries         | 8 Desalination industries | 12 Higher Pressure HVAC Applications |

Specific descriptions, dimensions and construction details illustrated may vary slightly from this bulletin. They are for general use only. We reserve the right to revise or modify product design without prior notice.

# BUTTERFLY VALVES - DOUBLE OFFSET / ECCENTRIC DESIGN

## STANDARD PARTS LIST

NO	Part	Qty	Material		Code
1	Valve Body	1	Carbon Steel SS304 SS316 Ductile Iron	A216 Gr WCB A351 Gr CF8 A351 Gr CF8M ASTM A536	CS S4 SS DI
2	Seat Retainer	1	Carbon Steel SS304 SS316	AISI 1045 A204 Tp 304 A240 Tp 316	CS S4 SS
3	Seat	1	PTFE RPTFE Metal		T R M
4	Disc	1	SS304 SS316	A351 Gr CF8 A351 Gr CF8M	S4 SS
5	Disc Pin	2	SS304 17-4PH SS316	A276 Tp 304 A276 Tp 316	S4 S7 SS
6	Stem	1	SS304 SS316 17-4PH	A276 Tp 304 A276 Tp 316 A564 Gr 630	S4 SS S7
7	Packing Gland	1	SS41	A283-C	S
8	Packing Follower	1	SS304	A276 Tp 304	S4
9	Bottom Cover	1	Carbon Steel SS304 SS316	A576 Gr 1045 A276 Tp 304 A276 Tp 316	CS S4 SS
10	Retainer Bolt	1set	SS304 SS316	A193 Gr B8 A193 Gr B8M	S4 SS
11	Stem Bearing	2	Stainless Steel & RTFE		SS
12	Gland Bolt	2	SS304	A193 Gr B8	S4
13	Packing	1set	PTFE/GRAPHITE		T / G
14	Packing Retainer	1	Viton		V
15	Shaft Retainer	1	SS304 SS316	A276 Tp 304 A276 Tp 316	S4 SS
16	Bottom Packing	1	PTFE		T
17	Bottom Bolt	4	SS304	A193 Gr B8	S4
18	O Ring	1	Nitrile		N
19	Stem Ball	1	Stainless Steel		S

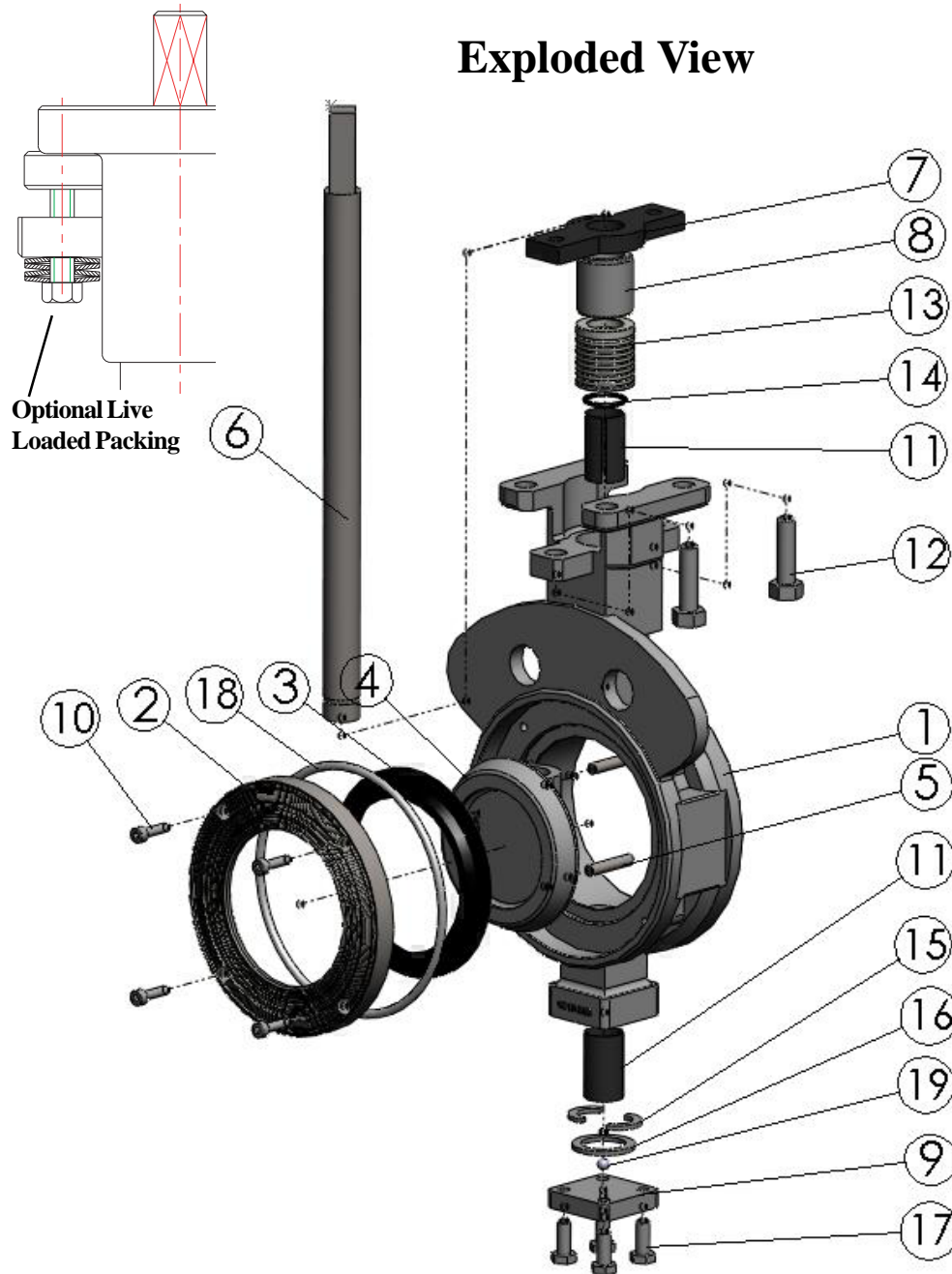

\*Special material can be produced to meet customer's special requirements.

## HIGH PERFORMANCE BUTTERFLY VALVE MODEL NUMBER CODES

Model	Pressure Class		Body Material		Disc Material		Stem Material		Seat Material		Stem Seal		Operator	
Wafer-BW	150	630	316SS	SS	316SS	SS	316SS	SS	PTFE	T	PTFE	T	Lever	L
	300	730	WCB	CS	304SS	S4	17-4ph	S7	RPTFE	R	RPTFE	R	Gear	G
Lug-BL	600	830	Ductile Iron	DI			304SS	S4	Metal	M	Graphite	G	Bare stem	N

## ORERING EXAMPLE BY PART NUMBER

Wafer	Class150	316SS	316SS	17-4ph	RPTFE	Graphite	Lever
Model	Pressure Class	Body	Disc	Stem	Seat	Stem Seal	Operator
BW	630	- SS	- SS	- S7	- R	- G	- L



## SEVERE SERVICE-METAL SEATED VALVES

The Max-Seal metal seated valves are designed to provide high performance service in abrasive, dirty and/or high temperature applications. Uniquely designed for reliable, tight shut-off performance up to ANSI-FCI 70-2 Class V leakage criteria.

### Metal Seat High Performance Butterfly Valve

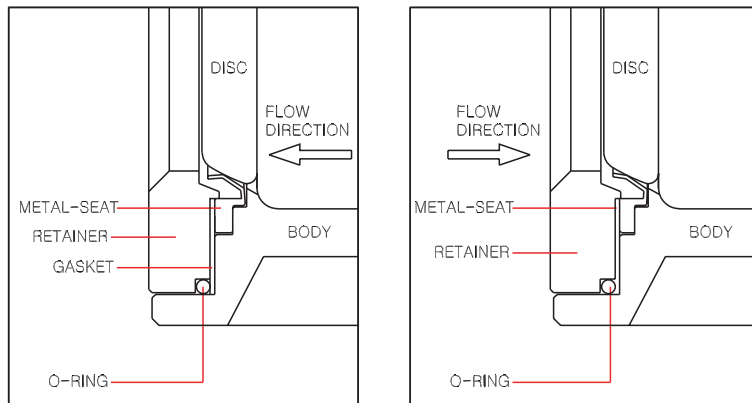

Seat Material    Maximum Working Temperature  
 METAL-SEAT 399°C (750°F) (316L)  
 Class V of ANSI B16. 104 leakage rate.

### PRODUCT IDENTIFICATION:

=MAX-SEAL=	
Model #:	_____
Trim:	_____
Size:	_____
Rating:	_____
Body	<input type="text"/>
Disc	<input type="text"/>
Seat	<input type="text"/>
Psi/CWP	<input type="text"/>
Max-T	<input type="text"/>
No.:	_____
Date:	_____
www.flotite.com	

Every Max-Seal valve has a special identification tag attached to the valve body. Information includes valve figure number, the size and pressure class, the materials of construction, and the operating pressures and temperatures.

The metal tag also includes a serial number; The serial number is recorded by the Flo-Tite Quality Control Department along with the test results and material certification data, for individual traceability and certification of every valve produced.

### PRESSURE TEMPERATURE RATING:

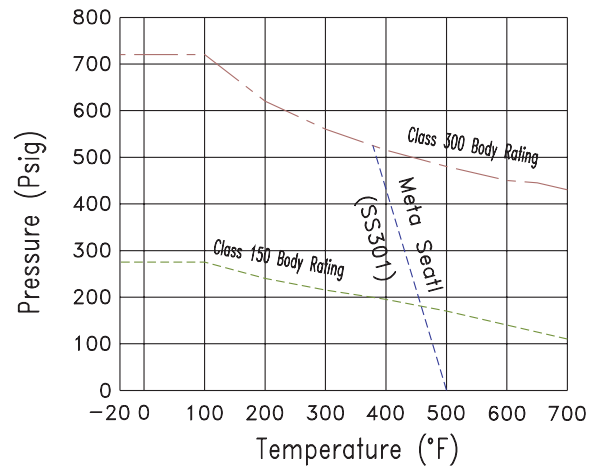

### Standard Specifications

- Body Style: Wafer, Lug
- Valve Size: 2" - 40" (50-1000mm)
- Rating: ANSI Class 150, ANSI Class 300
- Applicable Flange Standard: ANSI B16.5
- Face to Face Dimensions: API 609, MSS SP68, ISO5752
- Actuator Mounting Flange: ISO 5211
- Valve Design: MSS SP-68
- Valve Design: API 609
- Valve Marking: MSS SP-25
- Valve Testing: API 598 Inspection and Testing
- Valve Testing: MSS SP-61 Testing of Steel Valves
- Valve Design: ANSI B16.34
- Valve Material: NACE MR-01-TS
- Valve to have Official API Monogram
- Valve to API Specification Q1
- Valve to API ISO 9001:2000
- Valve to ISO/TS 29001



A wider selection of higher pressures & sizes reaching up to 120 inch, ANSI Class 300, 600 & 900 are available on a special order basis.

### Every Valve is Strength Tested

Shell tested to 150% of rated pressure with the disc open... hydrostatic seat tested for bi-directional positive shutoff without leakage at 110% of rated pressure. We also test for absence of leakage into valve shaft bearing areas. Only valves meeting a positive shutoff standards are approved for shipment.

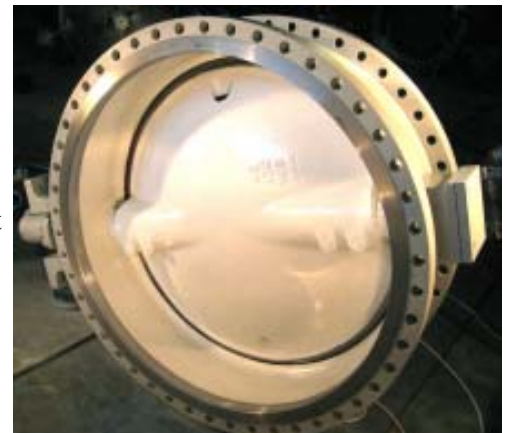

**www.flotite.com**

# DIMENSION DATA:

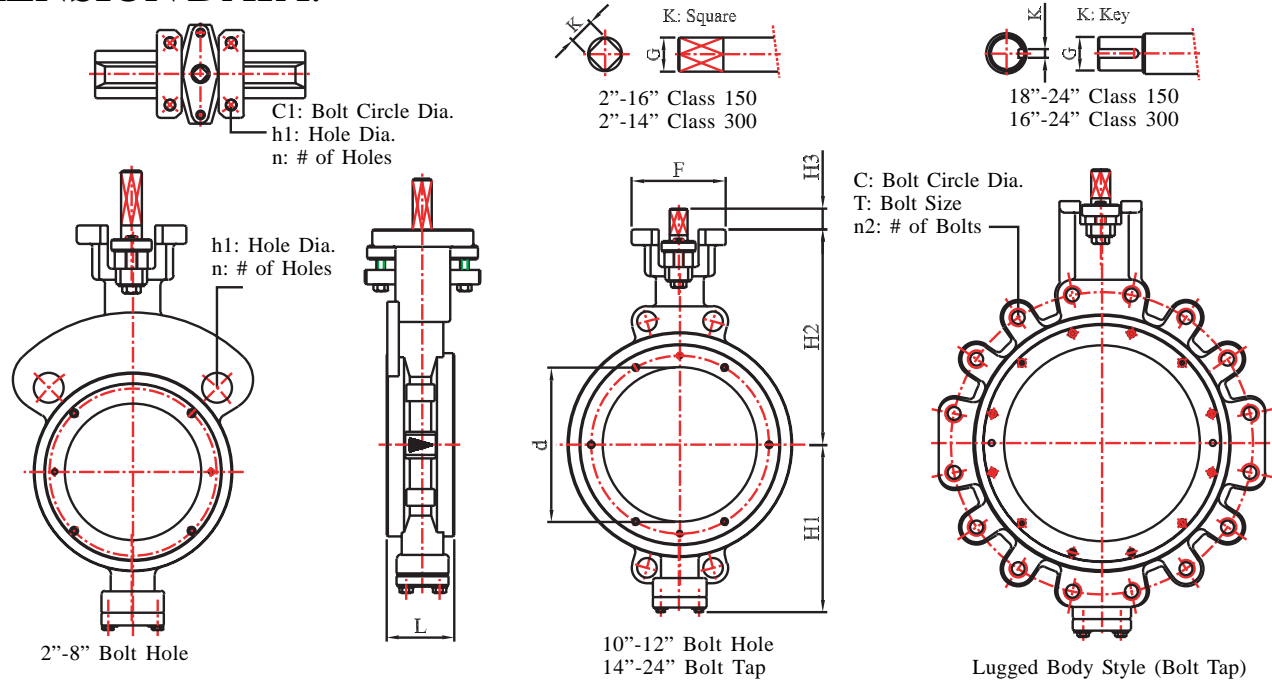

**Note**

1. Face to face Dimension: comply to API 609 Category B, ISO-5752 Short
2. End Connection Flange Dimension: comply to ANSI-B16.47

C/F Factory for larger sizes from 28'' thru 42''

## ANSI Class 150 High Performance Butterfly Valves - Model 630

SIZE		d	L	H1	H2	H3	F	G	K	Flange Dimension					Mounting Base			
inch	mm									C	h	T	N1	N2	C1	n	h1	ISO
2	50	1.93	1.69	3.27	4.84	1.38	2.76	0.512	0.433	4.75	0.75	5/8-11unc	2	4	2.76	4	0.39	F07
2.5	65	2.44	1.85	3.70	5.67	1.38	2.76	0.512	0.433	5.50	0.75	5/8-11unc	2	4	2.76	4	0.39	F07
3	80	2.87	1.89	4.09	6.06	1.38	2.76	0.630	0.551	6.00	0.75	5/8-11unc	2	4	2.76	4	0.39	F07
4	100	3.70	2.13	4.76	6.85	1.38	2.76	0.630	0.551	7.50	0.75	5/8-11unc	2	8	2.76	4	0.39	F07
5	125	4.80	2.24	5.43	7.60	1.38	2.76	0.630	0.551	8.50	0.875	3/4-10unc	2	8	2.76	4	0.39	F07
6	150	5.71	2.24	6.50	8.27	1.38	2.76	0.866	0.669	9.50	0.875	3/4-10unc	2	8	2.76	4	0.39	F07
8	200	7.64	2.52	7.76	9.84	1.97	4.53	1.102	0.866	11.75	0.875	3/4-10unc	2	8	4.02	4	0.47	F10
10	250	9.29	2.83	8.35	10.83	1.97	4.53	1.378	1.063	14.25	1.00	7/8-9unc	4	12	4.02	4	0.47	F10
12	300	10.94	3.19	10.24	12.05	1.97	5.12	1.378	1.063	17.00	1.00	7/8-9unc	4	12	4.92	4	0.67	F12
14	350	12.52	3.62	11.42	12.99	1.97	5.12	1.378	1.063	18.75	1.125	1-8unc	4	12	4.92	4	0.67	F12
16	400	14.17	4.02	12.99	15.35	2.17	6.50	1.772	1.417	21.25	1.125	1-8unc	4	16	6.50	4	0.91	F16
18	450	17.05	4.49	14.17	16.73	2.95	6.50	1.969	5/8 x 5/8	22.75	1.25	1-1/8-8unc	4	16	6.50	4	0.91	F16
20	500	18.50	5.00	15.35	17.72	2.95	6.50	2.165	3/4 x 1/2	25.00		1-1/8-8unc	4	20	6.50	4	0.91	F16
22	550	20.47	6.06	16.73	19.49	3.15	9.84	2.362	3/4 x 1/2	27.25		1-1/4-8unc	4	20	6.50	4	0.91	F16
24	600	22.83	6.06	17.32	20.08	3.54	9.84	2.559	3/4 x 1/2	29.50		1-1/4-8unc	6	20	10.0	4	0.91	F25

## ANSI Class 300 High Performance Butterfly Valves - Model 730

SIZE		d	L	H1	H2	H3	F	G	K	Flange Dimension					Mounting Base			
inch	mm									C	h	T	N1	N2	C1	n	h1	ISO
2	50	1.93	1.69	3.27	4.84	1.38	2.76	0.512	0.433	5.00	0.75	5/8-11unc	2	8	2.76	4	0.39	F07
2.5	65	2.44	1.85	3.70	5.67	1.38	2.76	0.512	0.433	5.88	0.875	3/4-10unc	2	8	2.76	4	0.39	F07
3	80	2.87	1.89	4.09	6.06	1.38	2.76	0.630	0.551	6.62	0.875	3/4-10unc	2	8	2.76	4	0.39	F07
4	100	3.70	2.13	4.76	6.85	1.38	2.76	0.630	0.551	7.88	0.875	3/4-10unc	2	8	2.76	4	0.39	F07
5	125	4.80	2.24	5.43	7.60	1.38	2.76	0.630	0.551	9.25	0.875	3/4-10unc	2	8	2.76	4	0.39	F07
6	150	5.71	2.32	6.50	8.27	1.38	2.76	0.866	0.669	10.62	0.875	3/4-10unc	2	12	2.76	4	0.39	F07
8	200	7.64	2.87	8.27	9.84	1.97	4.53	1.102	0.866	13.00	1.00	7/8-9unc	2	12	4.02	4	0.47	F10
10	250	9.25	3.27	9.45	11.02	1.97	4.53	1.378	1.063	15.25	1.125	1-8unc	4	16	4.02	4	0.47	F10
12	300	10.87	3.62	10.63	12.60	1.97	5.12	1.378	1.063	17.75	1.250	1-1/8-8unc	4	16	4.92	4	0.67	F12
14	350	12.44	4.61	12.60	14.57	2.17	5.12	1.772	1.417	20.25		1-1/8-8unc	4	20	4.92	4	0.67	F12
16	400	14.09	5.24	14.17	16.54	2.95	6.50	1.772	5/8 x 3/8	22.50		1-1/4-8unc	4	20	6.50	4	0.91	F16
18	450	16.93	5.87	15.75	18.11	3.54	6.50	1.969	5/8 x 3/8	24.75		1-1/4-8unc	4	24	6.50	4	0.91	F16
20	500	18.43	6.26	17.72	19.69	3.54	6.50	2.165	3/4 x 1/2	27.00		1-1/4-8unc	4	24	6.50	4	0.91	F16
24	600	22.76	7.13	20.47	22.44	3.54	9.84	2.559	3/4 x 1/2	32.00		1-1/2-8unc	6	24	10.0	4	0.91	F25

# HANDLE AND GEAR OPERATOR DIMENSIONS

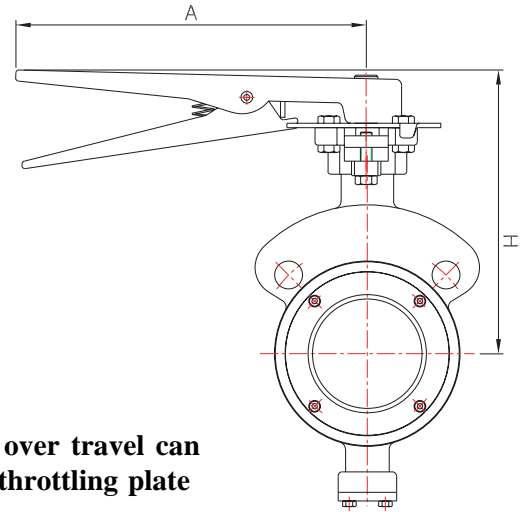
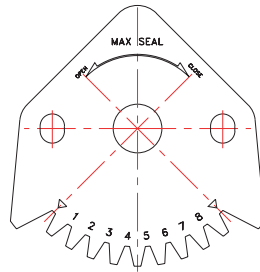
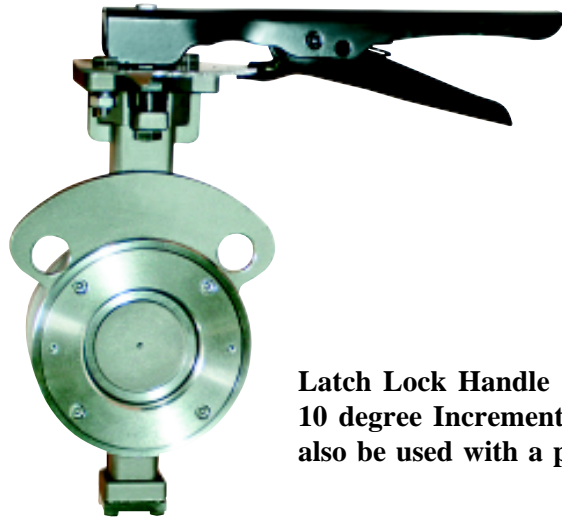

**Latch Lock Handle**  
 10 degree Increments with off stop to prevent over travel can also be used with a padlock. Optional: infinite throttling plate

## LOCK-LEVER TYPE HANDLE

SIZE	2"	2.5"	3"	4"	5"	6"	8" & larger
H	6.46	7.28	7.68	8.46	9.06	9.84	Gear Operator is recommended
A	9.06	9.06	9.06	9.06	10.43	10.43	

## WORM GEAR TYPE OPERATOR(ANSI CLASS 150)

SIZE	2"	2.5"	3"	4"	5"	6"	8"	10"	12"	14"	16"
H	8.58	9.41	9.80	10.59	12.17	12.95	16.26	17.24	20.63	21.57	23.94
C	4.72	4.72	4.72	4.72	6.69	6.69	9.84	9.84	13.78	13.78	13.78
A	4.72	4.72	4.72	5.12	5.12	5.12	8.66	8.66	11.22	11.22	11.22

SIZE	18"	20"	22"	24"	26"	28"	30"	32"	34"	36"	40"
H	25.59	26.77	28.54	39.13	37.80	38.19	44.09	46.06	50.39	51.57	55.51
C	13.78	13.78	13.78	13.78	23.62	23.62	25.59	25.29	27.56	27.56	27.56
A	11.81	11.81	11.81	11.81	12.60	12.60	12.60	12.60	15.75	15.75	15.75

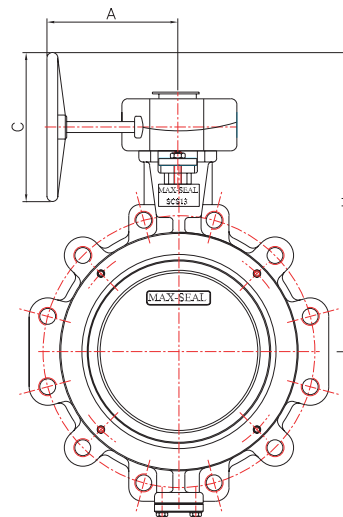

**Max-Seal offers a broad line of automation systems for precise proportioning or on-off control in either pneumatic or electrically powered units.**

Actuator mounting flange - universally designed to mount valve automation equipment, complying to ISO 5211. Sizes 2" thru 16" Class 150 & 2" thru 14" C; ass 300 can be directly mounted, larger sizes require a mounting bracket. For direct mount option, a mounting plate spacer is usually needed to compensate the long shaft of butterfly valves.



# VALVE FLOW COEFFICIENTS & TECHNICAL DATA

## MAXSEAL 630, 730 SERIES CV VALUE

SIZE		Angle of Opening							
INCH	MM	90°	70°	60°	50°	40°	30°	10°	
2	50	150	93	65	46	31	21	13	2
		300	93	65	46	31	21	13	2
2 1/2	65	150	152	106	76	52	35	21	4
		300	152	106	76	52	35	21	4
3	80	150	263	184	133	89	61	36	6
		300	263	184	133	89	61	36	6
4	100	150	465	329	237	164	107	65	14
		300	465	329	237	164	107	65	14
5	125	150	768	545	394	263	177	106	22
		300	768	545	394	263	177	106	22
6	150	150	1162	813	606	404	268	167	40
		300	1162	813	606	404	268	167	40
8	200	150	2121	1505	1091	742	490	293	66
		300	1919	1364	990	672	444	268	61
10	250	150	3232	2293	1697	1131	742	449	101
		300	2828	2005	1485	990	651	394	91
12	300	150	4747	3419	2545	1661	1091	667	152
		300	4141	2985	2222	1449	954	581	131
14	350	150	5858	4101	2879	1970	1348	818	192
		300	5555	3889	2732	1869	1278	778	182
16	400	150	8080	5727	3939	2747	1838	1121	253
		300	7676	5439	3742	2611	1747	1066	237
18	450	150	10605	7474	5353	3555	2288	1475	343
		300	9999	7050	5050	3353	2192	1389	323
20	500	150	14140	9999	7070	4848	3232	1959	434
		300	13130	9582	6565	4505	3000	1818	404
24	600	150	21210	15049	10807	7373	4878	2969	657
		300	19695	13978	10039	6848	4530	2757	611
26	650	150	25250	17877	12827	8686	5757	3535	788
		300							
28	700	150	28381	20139	14403	9807	6555	4010	667
		300							
30	750	150	33835	26391	15902	11166	7444	4737	677
		300							
32	800	150	41410	29391	21109	14140	9494	5757	1162
		300							
36	900	150	55550	43329	26109	18332	12221	7777	1111
		300							
40	1000	150	70700	55146	33229	23331	15554	9898	1414
		300							
Pressure Recovery Factor FL		0.59	0.61	0.68	0.74	0.80	0.82	0.88	

## MAXSEAL 630 SERIES TORQUE VALUE, Class 150

SIZE		Soft Seated				Metal Seated			
INCH	MM	70 psi	150 psi	210 psi	285 psi	70 psi	150 psi	210 psi	285 psi
2	50	218	244	261	270	435	479	487	496
2 1/2	65	318	341	365	400	636	671	682	735
3	80	387	429	456	525	787	829	856	927
4	100	458	536	615	720	1008	1099	1151	1193
5	125	785	882	962	1250	1458	1634	1746	2067
6	150	978	1215	1417	1535	1890	2007	2125	2262
8	200	1327	1857	1960	2270	2535	2786	3095	3417
10	250	2099	2657	3200	3700	3599	4199	4956	5549
12	300	2918	3824	4729	5635	4528	5837	7144	8375
14	350	4325	5610	7165	9100	7913	10385	12858	13813
16	400	5624	7652	9734	12775	9464	13248	15614	21523
18	450	8130	10904	13356	17350	13380	17846	21811	25062
20	500	10022	15818	17182	24000	17454	22909	29454	37028
24	600	15195	20894	26117	31340	23268	30391	37513	47009

## MAXSEAL 730 SERIES TORQUE VALUE, Class 300

SIZE		Soft Seated				Metal Seated			
INCH	MM	150 psi	350 psi	600 psi	740 psi	150 psi	350 psi	600 psi	740 psi
2	50	353	444	466	478	671	727	773	784
2 1/2	65	444	554	596	610	846	915	970	1025
3	80	475	601	654	685	894	1006	1048	1160
4	100	674	980	1072	1180	1379	1608	1900	2007
5	125	975	1388	1618	1800	1866	2229	2543	2725
6	150	1138	1611	1862	1965	1891	2438	2777	2999
8	200	2055	2805	3278	3538	3309	4533	5266	5511
10	250	2888	4470	5282	5892	4571	6965	7952	8489
12	300	3992	6666	8039	8627	6092	12604	15237	17856
14	350	5891	11577	14472	15925	10136	17366	22190	24119
16	400	8847	16774	20323	22356	14227	25404	33534	35566
18	450	11749	13447	27769	29904	19225	36313	48060	52874
20	500	18577	33119	39141	42152	26872	53744	72938	79336
24	600	24193	41399	51232	54845	35190	65980	89074	98970

### Flow Data Rated Cv

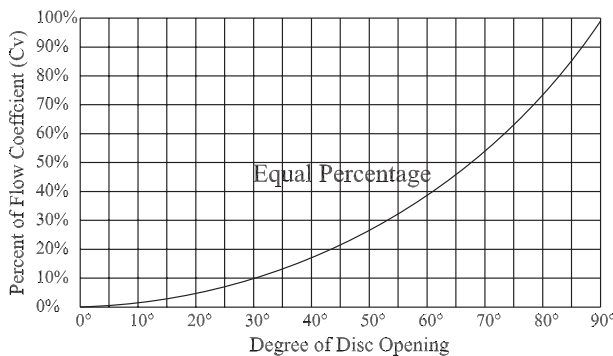

The volume of water in United States gallons per minute that will pass through a given valve opening with a pressure drop of 1 pound per square inch. (water at temp=60 deg.f)

### Valve Torque Vs Degree of Disc Opening

The torque in the table above is rated for maximum pressure drop when valve is in the closed position. Butterfly valve torque varies from full close to full open. It generally follows as indicated in the chart on the right.

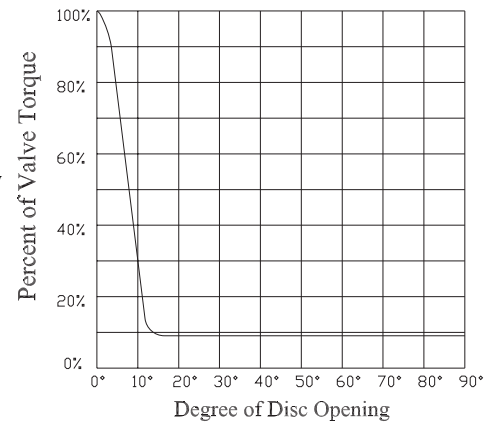

Flo-Tite, Inc.  
305 East 21st Street  
Lumberton, NC 28358

Tel: (910) 738-8904  
Fax: (910) 738-9112  
E-mail: [flotite@nc.rr.com](mailto:flotite@nc.rr.com)

P.O. Box 1293  
Lumberton, NC 28359  
Website: [www.flotite.com](http://www.flotite.com)

